

## Master Plan

### Prestige

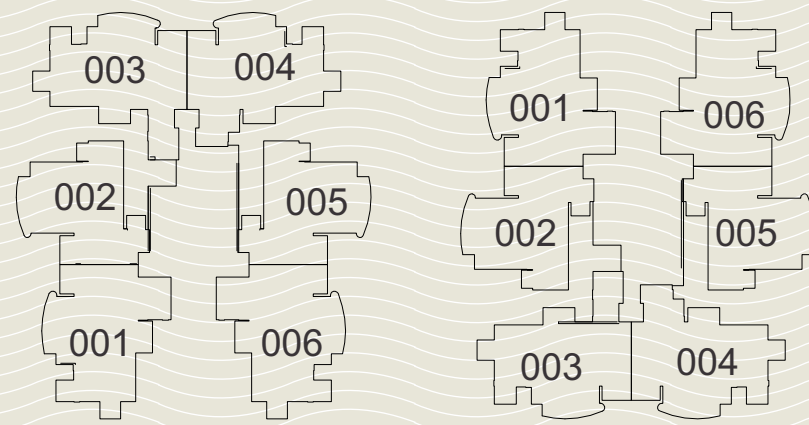

P (I)

P (II)

### Privilege

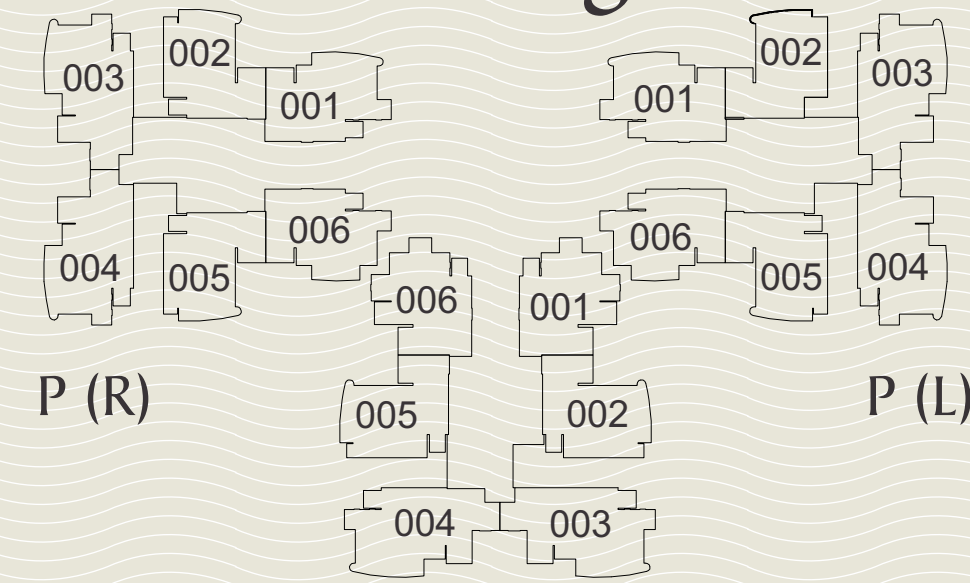

P (R)

P (L)

P (C)

### Acclaim

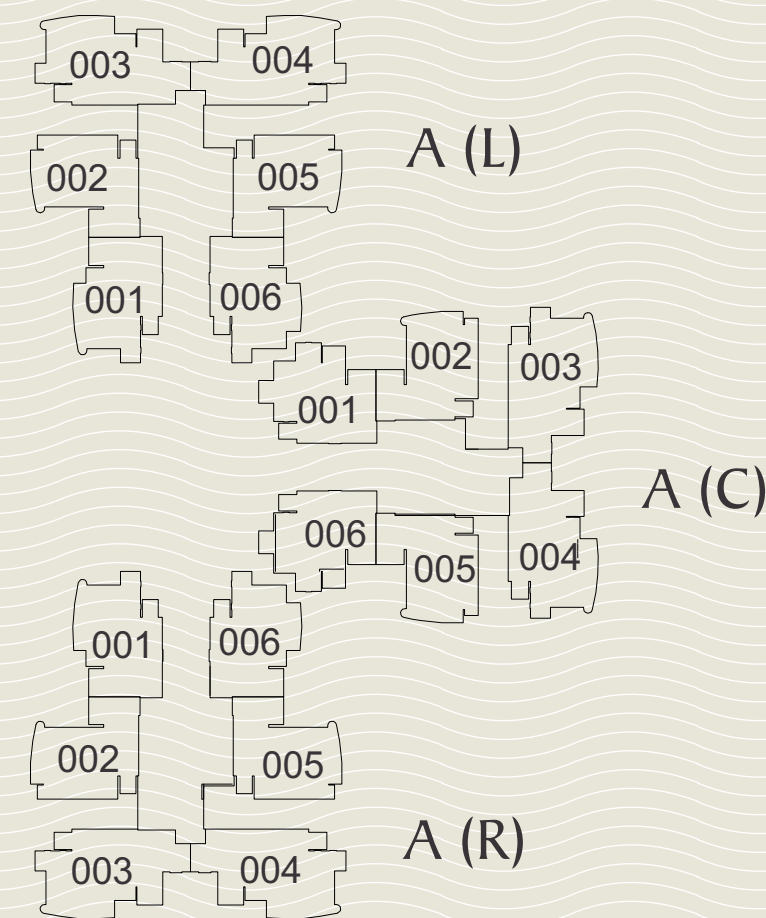

A (L)

A (C)

A (R)

A	2122 sq. ft	3 B/R + Servant	C	1457 sq. ft	2 B/R + Study
B	1751 sq. ft	3 B/R + Servant	D	1264 sq. ft	2 B/R

#### DISCLAIMER

- The overall Master Plan may vary because of statutory reasons in case required
- The above plan is indicative, conceptual and subject to change
- The project will be developed in phase wise manner.
- Please go through the detailed terms of allotment before making a booking.
- The terms of Allotment Agreement shall have precedence over the given Master Plan.

Prestige (I)

Prestige (II)

Acclaim (L)

Acclaim (R)

Privilege (R) Privilege (L)

Privilege (C)

Acclaim (C)



#### LEGENDS:-

- |                         |                         |                             |                            |                        |                      |
|-------------------------|-------------------------|-----------------------------|----------------------------|------------------------|----------------------|
| 1 GATE HOUSE            | 5 PRESTIGE (I) - G +II  | 9 ACCLAIM (R) - G +17       | 13 SCHOOL (G+3)            | 17 SWIMMING POOL       | 21 LANDSCAPED GREENS |
| 2 PRIVILEGE (L) - G +17 | 6 PRESTIGE (II) - G +12 | 10 COMMUNITY BUILDING (G+I) | 14 ROUGH & TOUGH PLAY AREA | 18 BASEMENT ENTRY/EXIT | DG EXHAUST SHAFT     |
| 3 PRIVILEGE (C) - G +18 | 7 ACCLAIM (L) - G +17   | 11 COMMERCIAL               | 15 KID'S PLAY AREA         | 19 EWS ENTRY           | BASEMENT CUTOUT      |
| 4 PRIVILEGE (R) - G +17 | 8 ACCLAIM (C) - G +18   | 12 EWS (G+8)                | 16 PLAY COURT              | 20 SCHOOL ENTRY        | PRIVATE PARKING      |